

**FASTWAY**

For Models: 88-00-6265 (side-wind jack)  
88-00-5165 (top-wind jack)



# Installation and Operation Instructions



2 1/4" Flip™ jack foot with  
Side-wind Jack



2 1/4" Flip™ jack foot with  
Top-wind Jack

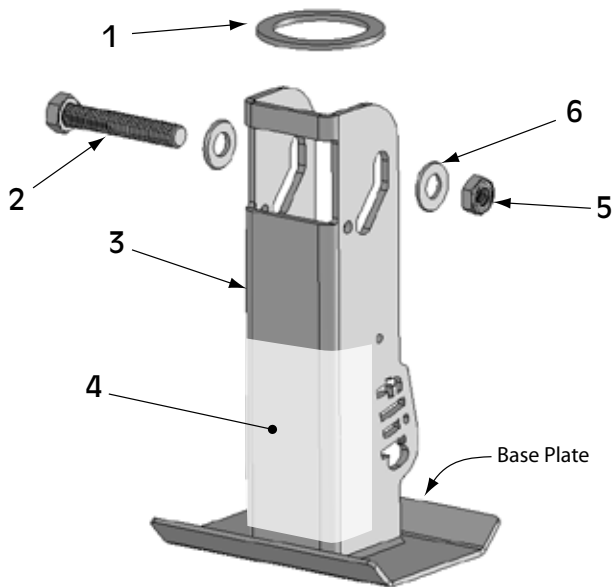

### **Tools Needed for Installation:**

- (2) 3/4" wrenches for Flip installation
- 9/16" wrench for jack mounting bolts
- 9/16" wrench for jack handle assembly

### **Parts Breakdown**

Fig. #	Part #	Description	Qty.
1	88-01-6200	Spacer Ring (2" I.D.)	1
2	88-01-6150	1/2" x 3" bolt	1
3	88-01-6600	Flip Automatic Jack Foot	1
4	BD088-WS	Warning Sticker	1
5	90-04-9285	1/2" Nylock Jam Nut	1
6	90-04-9110	1/2" Washer	2
Not shown	88-02-5111	Handle Assembly and Hardware – Top-wind Jack	1
Not shown	88-02-6211	Handle Assembly and Hardware – Side-wind Jack	1
Not shown	88-03-6219	Replacement Gear/Retaining Pin Package – Side-wind Jack	1
Not shown	88-03-6217	Plastic Gear Cavity Cover and Retaining Screw – Side-wind Jack	1

## **⚠️ WARNING**

- **Read entire instruction manual before using this product. Failure to do so can result in serious injury or death.**
- **Never exceed maximum tongue weight and capacity ratings.**
- **Do not use Flip jack foot to support trailer parked on grade greater than 3% (1.75°).**
- **Chock tires on both sides of trailer and in both directions while supporting trailer with jack foot.**
- **Do not support trailer with jack foot placed on un-level ground or debris. Jack foot base plate must be in complete contact with ground.**
- **Support tongue weight with jack foot in vertical position only when attachment bolt is resting at bottom of guide slot.**
- **Replace worn or faded safety labels immediately.**
- **Before each use inspect jack tubes and replace if bent or damaged.**

## **⚠️ CAUTION**

- **Always use adequate personal protective equipment when installing.**
- **Avoid pinch points between jack extension, spacer ring, jack, and trailer frame when retracting jack.**

# Installation



Never exceed maximum equipment ratings.

## **STEP 1**

**Locate trailer on a flat level surface**, such as a driveway or parking lot (*Figure 1*). Chock both sides of the trailer in both directions, and set tow vehicle parking brake. Keep trailer coupled to tow vehicle, or place jack stands under trailer tongue to support trailer without the use of the tongue jack. Disconnect trailer plug, safety chains, and safety breakaway cable from the tow vehicle and move them out of the way.

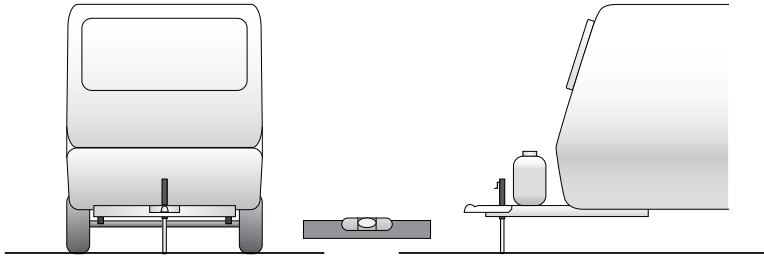

*Install jack and Flip™ jack foot with trailer parked on level ground both side-to-side and front-to-back.*

*Figure 1*



**Always wear adequate personal protection equipment while installing.**  
**Wear safety glasses.**

## **STEP 2**

**If your current jack is an electric model (if not skip to STEP 3):**

- a) Disconnect the negative battery cable to make sure there is no power being supplied to the jack.
- b) Disconnect any positive or negative power leads to the jack, and cap them appropriately where necessary.

## **STEP 3**

**Remove current jack:**

Using a wrench, remove the bolts, nuts and washers that secure the jack mounting plate to the trailer's A-frame coupler. Remove the jack from the coupler.

## **STEP 4**

### **Install new Fastway® jack:**

- a) Remove the jack from the packaging.
- b) Assemble the handle (For side-wind only, see Figure 2).
- c) Slide the jack down through the A-frame mounting hole.
- d) Align the jack over the mounting holes so that the Flip jack foot mounting holes, on the inner-tube of the jack, are perpendicular to the trailer. For the side-wind jack, the handle should be on the front of the jack, pointing away from the trailer body toward the tow vehicle (See Figures 3 and 4).



*Figure 2*

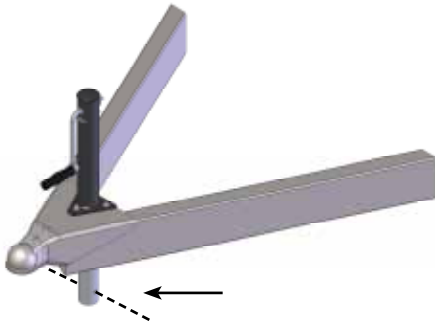

*Figure 3*

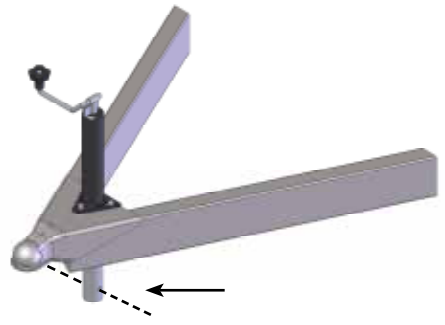

*Figure 4*

- e) Use the supplied 3/8" bolts, or your original mounting bolts, to mount the jack to the A-frame coupler.
  - i. Thread each bolt into the mounting holes by hand.
  - ii. Insert all bolts loosely before tightening any single bolt so that the jack is free to move to line up all three mounting holes, slots, and bolts.
- f) Tighten all bolts securely.
- g) Torque all bolts to between 15-20 ft. lbs.

## **STEP 5**

### **Install your Fastway Flip automatic jack foot:**

- a) Place the Flip jack foot below the jack so that the sticker faces forward toward the tow vehicle.
- b) Extend the jack until the inner-tube is low enough that you can easily see the pre-drilled mounting holes through the mounting slots in the Flip jack foot. DO NOT place any weight on the foot yet.



*Figure 5*

c) Slide the spacer ring up the inner jack tube and hold it up while you position the jack foot to bolt it on. Position the jack foot around the inner jack tube so that the slot at the top lines up with the 1/2" holes drilled in the jack tube (See *Figure 5*).

d) Slide a 1/2" washer onto the 1/2" bolt, and slide the bolt through the slots in the jack foot and holes in the jack tube. Slide the 1/2" washer onto the other end of the bolt, and thread on the Nylock nut (See *Figure 6*) Tighten the nut securely using two 3/4" wrenches. Then loosen it only to the point that the Flip jack foot can pivot freely up and down, but not enough that it is sloppy, or that there is too much play between the jack foot and the inner jack tube. If the jack foot does not drop smoothly into place, this nut may need to be loosened slightly.



*Figure 6*

## Instructions for Use

Never exceed Flip jack foot weight ratings.

Do not use to support trailer parked on grade greater than 3% (1.72°).

Do not support trailer with jack foot resting on un-level ground or debris.

Jack foot base plate must be in complete contact with ground.



### **STEP 6**

#### **When uncoupling your trailer:**

a) **Make sure that the trailer is parked on relatively level ground.** Most improved campsites, such as those found in private and public campgrounds are fine. Pay special attention to the site when dry camping to make sure the slope is not more than a 3% grade ( 1.72° ) either side-to-side or front-to-back (*Figure 7*).

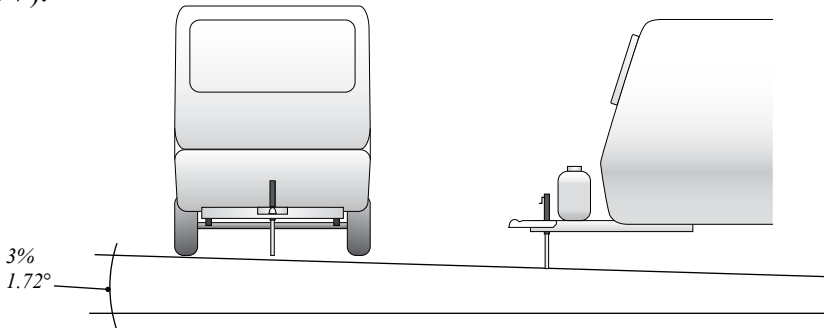

*Do not use Flip with trailer parked on a slope steeper than a 3% grade, or 1.72 degrees.*

*Figure 7*

b) Also make sure that the spot where the jack foot will rest is as level as possible, and free from debris like sticks or stones that might keep the jack foot from being completely supported.

c) Chock the wheels on both sides of the trailer and in both directions securely. Disconnect trailer plug, safety chains, and breakaway cable from the tow vehicle. Uncouple the coupler, and extend the jack to raise the coupler off the ball.

d) If using a weight distributing hitch, you may use the jack foot to raise both the tow vehicle and trailer to make it easier to disconnect the hitch. Once the spring arms are disengaged, lower the trailer and tow vehicle back to a point where the tow vehicle is supporting all of the trailer's tongue weight. Uncouple the coupler, and extend the jack to raise the coupler off the ball.



**Support tongue weight with jack foot in vertical position only when attachment bolt is resting at bottom of guide slot.**

## **STEP 7**

**The Flip jack foot is designed to straighten automatically as more weight is applied.**

At times it may be helpful to move it forward slightly with your foot to make sure it sits directly below the jack so that the jack tube rests correctly at the bottom of the bolt slot, and against the front of the jack foot or on top of the support/locating plate.

If the full tongue weight is placed on the jack with the jack foot out of position, the inner jack tube can bend, resulting in improper function of the jack or jack foot (*Figure 8*). It may also damage the jack foot or trailer.

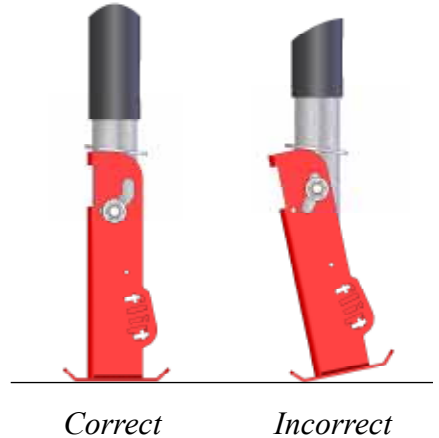

*Figure 8*

## **STEP 8**

**If you must drop the trailer in a place where there is not enough clearance below the jack for the Flip jack foot to pivot down properly, the jack may be extended with the jack foot in a horizontal position. A small block of wood placed directly under the inner jack tube will help keep the weight from damaging the Flip jack foot (*Figure 9*).**

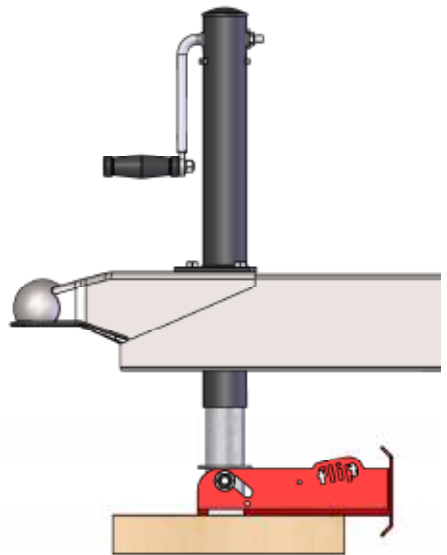

*Figure 9*

## **STEP 9**

### **To couple your trailer:**

Back the hitch ball under the coupler. Retract the tongue jack until the coupler rests on the hitch ball. Lock the coupler. If you are using a weight distributing hitch, extend the jack and tension the weight distribution bars.

Retract the jack completely until

the flip rotates up and out of the way for towing. Do not force the jack handle after the jack has reached the top of travel. Rotate it back slightly if necessary for towing (*Figure 10*).

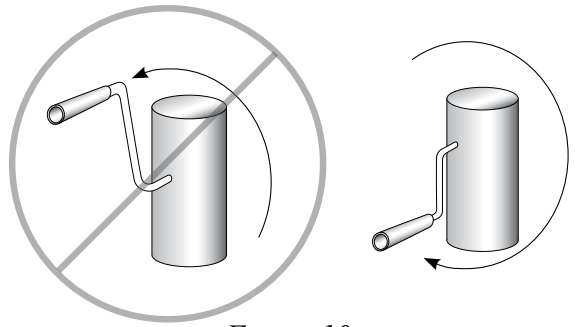

*Figure 10*

## **Maintenance**

### **Jacks:**

Before each use, check to make sure all bolts on the handle, mounting plate, and jack foot are secure and properly tightened.

### **Top-wind & Side-wind**

Periodically apply gear lubricant using the grease zerk located at the top of the jack tube.

### **Sidewind**

Periodically remove plastic gear cavity cover and coat bevel gears with a good quality gear lubricant/grease.

### **Flip Jack Foot:**

To keep foot swinging freely, lubricate contact points on pivot ring and top of Flip jack foot. Do not use petroleum based grease. Use a wax-based bicycle chain lubricant or a spray-on, silicone-based lubricant that naturally repels dust and dirt. (See *Figure 11*).

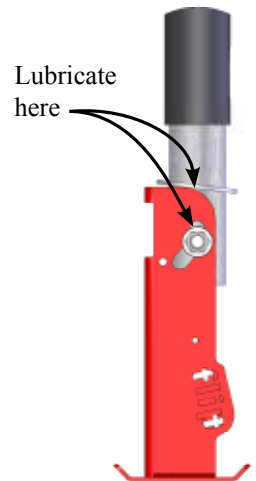

*Figure 11*

## Limited Warranties

*Progress Mfg. Inc. warrants, to the original purchaser, this product against defects in the materials and workmanship for a period of one year, from the date of purchase. This warranty does not cover damage due to normal wear and tear, misuse, neglect, abuse, or product finish. Progress Mfg. Inc. reserves the right to repair or replace the defective part(s) at their discretion. Replacement of product or refund constitutes the fulfillment of all liabilities of Progress Mfg. Inc. under this warranty. For questions about warranty coverage and warranty authorization, please call (877) 523-9103. If warranty repair or replacement is approved, send the entire product and proof of purchase, shipping pre-paid, to: Progress Mfg. Inc., 533 South 500 West, Provo, UT 84601*

# **Fastway e2 Hitches**

Less Hassles - Less Stress - Safer Towing



**e2™ Round Bar Hitch**



**e2™ Trunnion Hitch**

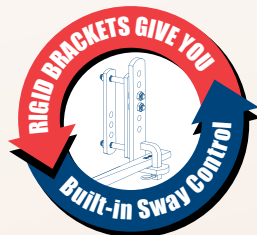

## **Integrated Sway Control™ - less hassles**

- Sway control built-in
- No add-on sway bar hassles or restrictions
- Excellent weight distribution
- Better steering and braking control

**Fastway e2 - Faster, Easier.™**

For more information visit [www.FastwayTrailer.com](http://www.FastwayTrailer.com)

# Other Great Fastway Products!

The Fastway® Zip™ breakaway cable's coiled design keeps your cable from dragging!

**Zip™**  
Trailer Breakaway  
Cable & Switch



Fastest and easiest tandem axle wheel chock ever!

**ONEstep™**  
tandem axle wheel chock

**Easy as...**



Fastway® Trailer Products  
533 South 500 West, Provo, UT 84601  
(877) 523-9103  
[www.FastwayTrailer.com](http://www.FastwayTrailer.com)

© 2010 Copyright Progress Mfg. Inc., All rights reserved.

JPIN\_0910

*All products US & foreign patents pending.*