



ONEstep™

Tandem Axle Wheel Chock

Instructions for Set-up and Use

1) Remove wheel chock from packaging, and remove the center cotter pin (a) and clevis pin (b) from the arms.

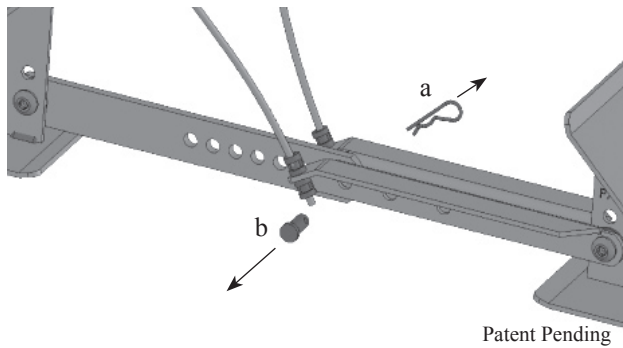

2) Set the chock between the tires and extend them out until the wedges touch the tires.

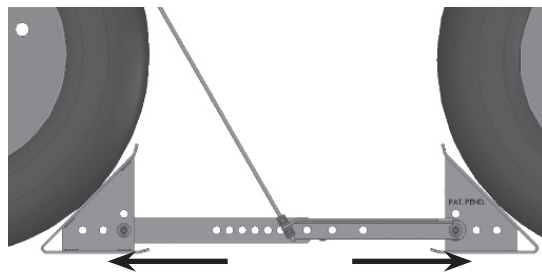

3) Slide the clevis pin into one of the holes in the arms to temporarily hold them in place. Don't insert the cotter pin yet.

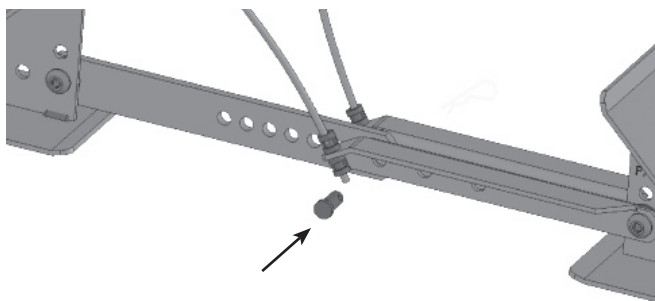

4) Remove the chock, and remove the clevis pin, then slide the arms apart until the next set of holes line up.

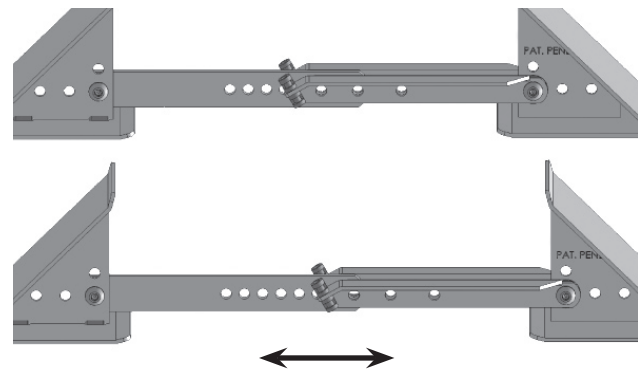

5) Place the clevis pin into one of the sets of holes, and then replace the cotter pin to secure it.

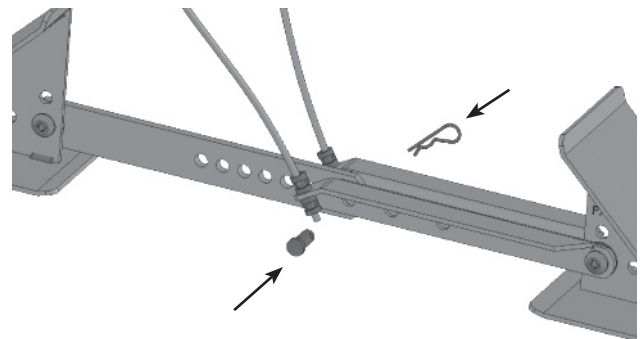

If you are not able to lengthen or shorten the chock to fit your axle spacing using the arm holes for adjustment, the bolts holding the ends of the scissor arms can be moved. Use the included hex key (Allen wrench) and a socket wrench to move the bolts to either of the other two adjustment holes in the wedges.

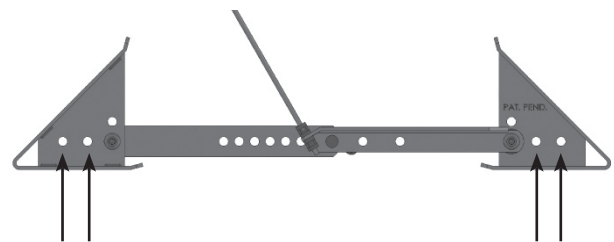

Warning

The Fastway® ONEstep™ Chock was designed to be used on level ground and gentle slopes. **Do not** use chock on grades that are excessive or unreasonably steep. Always remember to remove chock before attempting to tow trailer. Damage caused by driving over the wheel chock is not covered by warranty.

Some people prefer to place the pin off-center so that one arm hangs below the other. This allows them to ‘drag’ the chocks along the ground and open them up before sliding them under the tire.

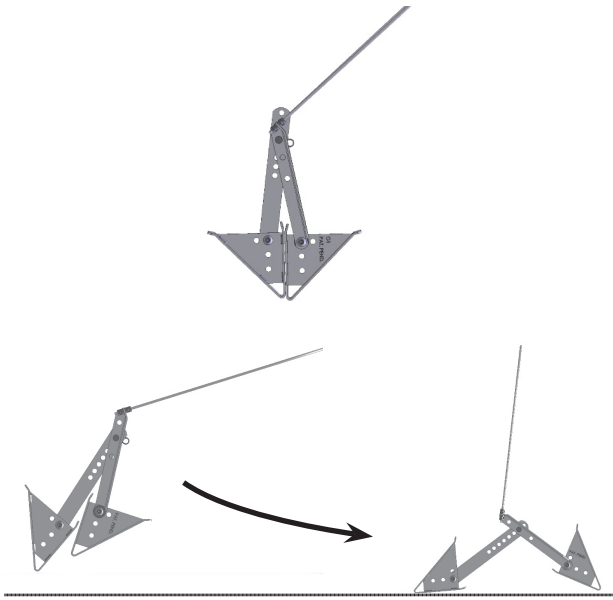

Others prefer to place the pin so that the arms hang at about the same length, and then step down on the tail ends of the wedges to force them open before sliding them between the wheels. Try each way a few times to see which works best for you.

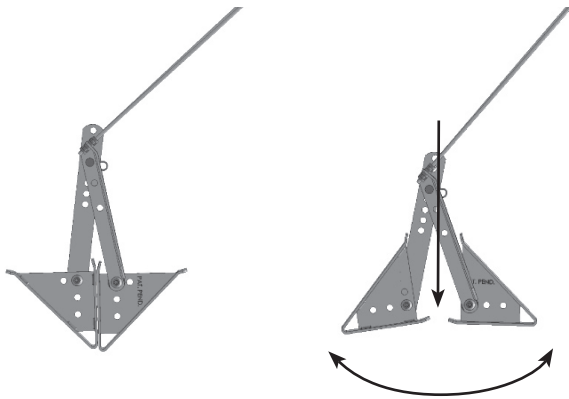

6) Slide the chocks into position between the tires so that the wedges are centered on the tread of the tire. Step down on the center of the arms to force them out against the tires and lock them into place.



7) Lean the cable handle against the tire so that it is within easy reach when you want to remove the chocks.

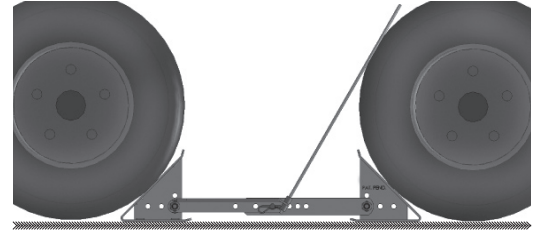

8) To remove the chocks, grasp the handle firmly in the middle and pull upward.

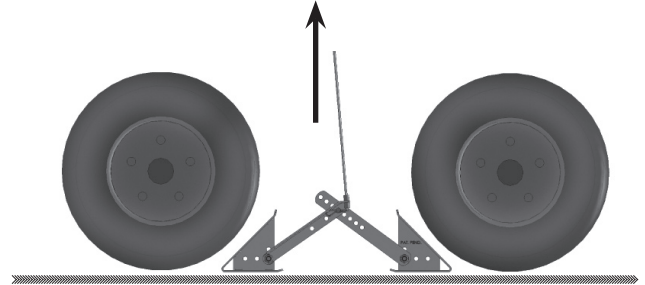

9) To lock the chock, step the chock into place tightly between the wheels. Place the padlock through one of the empty holes in the center of the arms, or through one of the lock holes in the wedges just above the scissor arms. Note: The lock is to be used as a theft deterrent. The lock will not guarantee the chocks can not be stolen.

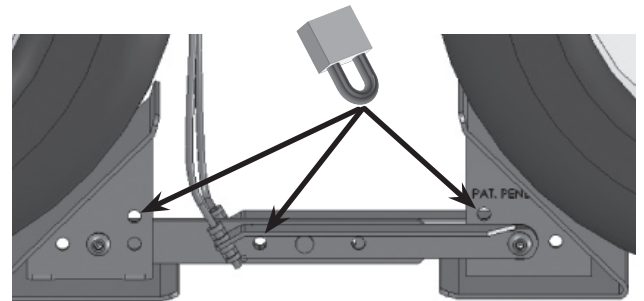

Limited One Year Warranty

Progress Mfg. Inc. warrants, to the original purchaser, this product against defects in materials and workmanship for a period of one year from date of purchase. This warranty does not cover damage due to normal wear and tear, misuse, neglect, abuse, or product finish. Progress Mfg. Inc. reserves the right to repair or replace the defective part(s) at their discretion. Replacement of product or refund constitutes the fulfillment of all liabilities of Progress Mfg. Inc. under this warranty. For questions about warranty coverage and warranty authorization, please call (800) 478-5578. If warranty repair or replacement is approved, send the entire product and proof of purchase, shipping pre-paid, to: Progress Mfg. Inc., 533 South 500 West, Provo, UT 84601



**533 South 500 West
Provo, UT 84601
www.FastwayRV.com
1-800-478-5578**